

**Prior to Use**

- Please read this instruction manual carefully.
- Please use product only as directed or severe damage to the product may occur.
- Not properly following these guidelines may result in extremely hazardous conditions that could cause electrical shock or fire.

**WARNING**

- Do not modify the product nor remove the protective enclosure. Under the protective enclosure are contained high voltage and high temperature components during normal operation and after complete shutdown. Avoid electric shock or burns by avoiding them.
- Under the protective enclosure are contained high voltage and high temperature components during normal operation and after complete shutdown. Avoid electric shock or burns by avoiding them.
- Keep face and hands away at all times during operation to avoid unexpected injury.
- DANGER. Risk of fire, electric shock, and injury. DO NOT continually operate if there is smoke, odor, or irregular noise. Instead immediately turn off the power and contact us. Do not attempt to repair it yourself because it is dangerous to do so.
- DANGER. Risk of fire, electric shock, and injury. DO NOT insert or drop any object in openings, this could cause unit failure or severe hazardous conditions.
- DANGER. Risk of fire, electric shock, and injury. DO NOT use the product with condensation present, this could result in electric shock or fire.

**CAUTION**

- This power supply is intended to be used as a component of a larger system of electrical equipment. User is responsible for the safe design when this product is to be integrated in the equipment which requires particularly high quality and reliability. There is a possibility to endanger persons or property by a failure or malfunction of this product.
- Avoid sharp and sudden impacts to this unit such as dropping or damage will likely result.
- Ensure and maintain input voltage, output current, output power, ambient temperature, and humidity within specification or unit may be damaged.
- Safety standards for this product are based on the condition that the product is to be used with forced air cooling. To prevent the temperature of internal parts from exceeding the specification, ensure that the product is exposed to proper airflow when installing
- Ensure that wires are properly secured to the input and output terminals as specified in this manual.
- Be sure to turn off the power before making the output connection.
- DO NOT use in a special environment (e.g. in the presence of strong electromagnetic field or erosive gas) or environment where conductive foreign substance is present.
- DO NOT use or store product where condensation may occur due to moisture or humidity. For use in such conditions, waterproof protection is necessary and must be installed.
- Do not operate under over current or short-circuit conditions for more than 10 seconds otherwise damage and electrical insulation failure will likely result.
- No stress (e.g. twist, deflection) should be applied to the print board when the product is installed.
- Avoid impacts, such as dropping this product.
- Do not apply the load to signal connector CN501.
- DANGER. Output of this product is regarded as hazardous energy so this should not be accessible to end users.
- Use appropriate connectors for the terminal connection.  
For the crimping of the contact, use the crimping tool recommended by the manufacturer.
- Prevent accidental contact with the output terminal of this product from dropped items such as tools by insuring proper orientation and shielding/cover.
- Turn off the input power and ensure that the input and output terminal voltage drops to zero.
- This product uses fuses in the double pole/neutral line. When it is used for information processing equipment (IEC/EN/UL62368-1,UL60950-1), the following label must be provided for service engineers.  
【CAUTION DOUBLE POLE / NEUTRAL FUSING】

Special Instructions for IEC/EN/UL60601-1

**CAUTION**

- These products are not suitable for use in the presence of flammable anesthetic mixtures with oxygen or with nitrous oxide.
- These products have not been assessed to IEC/EN/UL60601-1-2(EMC), but EMC test data is available from us.

Special Instructions for IEC/EN/UL62368-1(Annex R : Limited short-circuit test)

**CAUTION**

- Overcurrent protective device used for the test is as follows.

SIZE(mm)	Rated Current(A)	Voltage(Vac)	Breaking Capacity(kA)
10×38	20	500	120

# 1. Terminal Explanation

- Ensure AC power is off prior to connecting inputs and outputs.
- Connect FG terminal to earth terminal of device or equipment.
- Route AC and DC wires separately to minimize noise.
- Be sure to use each terminal (pole) of the terminal block at 20A or less.

• TERMINAL BLOCK (TB101)

L	: AC Line
N	: AC Neutral
	: Frame Ground
-V	: - Output terminal
-V	: - Output terminal
+V	: +Output terminal
+V	: +Output terminal

• Connector : CN501

+S	: + Output Remote Sensing	①
+VS	: + Output Voltage Check	②
-S	: - Output Remote Sensing	③
-VS	: - Output Voltage Check	④
	: Not in use	⑤
	: Not in use	⑥
+R	: +Remote Control ON/OFF	⑦
-R	: - Remote Control ON/OFF	⑧

CN502(not included)  
 Connector : S8B-PHDSS(JST)  
 Housing : PHDR-08VS  
 (Terminal) : SPHD-001T-P0.5  
 Crimping tool : AP-K2N

For proper connection to CN501 please assemble CN502 (not included) using parts above

**Front-View**

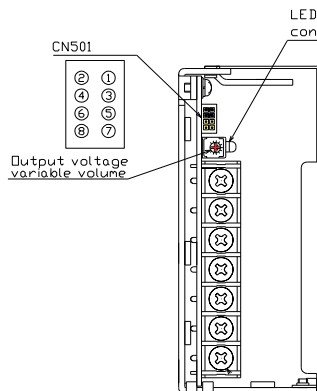

**Top - View**

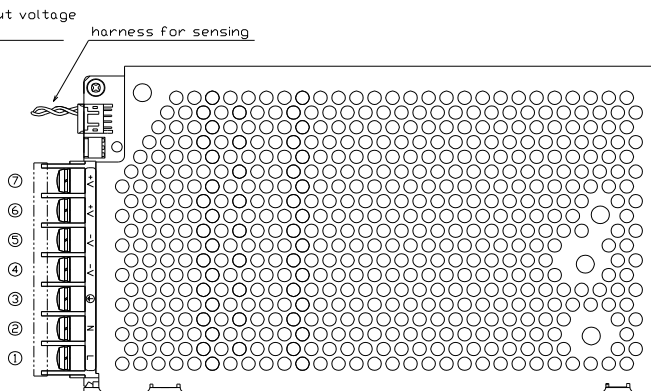

## 2. Function explanation

### 2-1 Input voltage

- AC input voltage range: 85-264VAC (47~63Hz)
- To avoid damage, please use within recommended range

### 2-2 Output voltage setting

- Adjust DC voltage output by using Output Adjustment Potentiometer located next to the CN501 connector.
- CW = increase, CCW = decrease.
- Use in the following range:
  - Within the rated output voltage  $\pm 10\%$  at the output terminal (For PFS300A-5, it a variable range of 4.5 to 6V.)
  - Do not exceed the maximum output power and rated output current.
- Slowly turn the potentiometer, not to exceed the rated voltage.

### 2-3 Inrush Current

- This unit comes with an integral inrush current limiting circuit using a power thermistor.
- Since SCR is used to prevent inrush current, the inrush current limiting circuit may have been released if the power is turned on again in a short time. Be sure to wait enough time before powering up again.
- Proper selection of component providing power (contactor, fuse, circuit breaker, etc...) to this unit requires ratings compatible with AC IN 100V : 20A / ACIN 200V : 40A (Ta=25°C Cold Start) due to internal SCR circuitry.

### 2-4 Over-current Protection(OCP)

- When it exceeds 110% of the rated output current, OCP shuts off the output.
- Turn off power and remove fault and wait a few minutes before powering up again.
- Avoid operation in the over current state longer than 10 seconds or damage to the power supply may occur.

### 2-5 Over-Voltage Protection(OVP)

- During an over voltage fault OVP circuitry will disable output until fault is removed and unit is allowed to reset.
- Once OVP is activated, output is continuously shut off as long as the input power is supplied
- Turn off power and ensure supplied voltage stays within tolerable limits (100-240VAC) and wait a few minutes before powering up again.
- After reset output voltage might be abnormal, so it should be confirmed and adjusted as needed.

### 2-6 Over Temperature Protection (OTP)

- During an over temperature fault OTP circuitry will disable output until fault is removed and unit is allowed to reset
- Turn off power and allow unit to cool by wait a few minutes before powering up again.
- Confirm the forced air convection allows for cooling airflow.

### 2-7 Remote Sensing

- The remote sensing function is built-in.
- Please note that the maximum allowable voltage drop from Load to CN terminal is 0.3V.
- Please twisted pair wires installed in parallel with load wire as shown below.

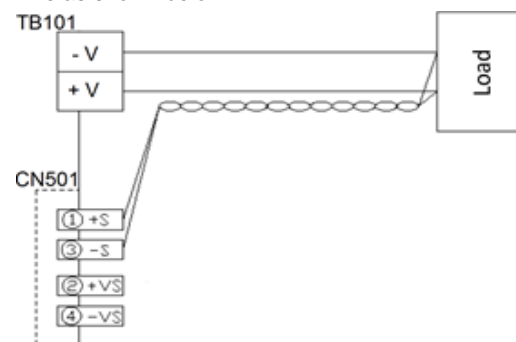

If no Remote Sensing will be used, please retain CN501 jumper connector as shown:



## 2-8 Remote On/Off

- This unit comes with an integral on/off circuit, see wiring diagram below.
- Unit DC output is disabled when control voltage is applied to RC terminal in reference to -V terminal.
- If SW is open or control voltage E is:  $0 < E < 4.5V$  then unit output is enabled.
- If SW is closed and control voltage E is:  $4.5VDC < E < 6.5VDC$  then output is disabled, and no need for current limiting resistor R.
- If SW is closed and control voltage E is:  $6.5VDC < E < 24.5VDC$ , then current limiting resistor R must be =  $(E - (1.1 + 1000 \times 0.005)) / 0.005$ . For example if  $E = 24VDC$ ,  $R = (24 - (1.1 + 5)) / 0.005 = 3.5k\Omega$

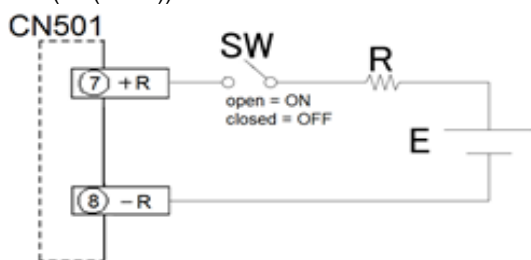

## 2-9 Series Operation

- This Daitron power supply unit is configurable in series with another Daitron power supply (if it too is configurable in Series) in order to increase DC voltage or to provide both "+" and "-" DC voltage.
- In these configurations the MAXIMUM current delivered to the Load is limited to the maximum allowable from the power supply with the lowest current rating.
- To increase VDC (PS1 + PS2) see configuration (1) below. Example: If PS1 and PS2 are both 12VDC/30W each, then configuration (1) will provide 24VDC/60W
- To provide both "+" and "-" DC voltage to a load see configuration (2) below. Example: If PS1 and PS2 are both 12VDC/30W each, then configuration (2) will provide +12VDC to Load1 and -12VDC to Load2, with a maximum total wattage of 60W for both loads combined.

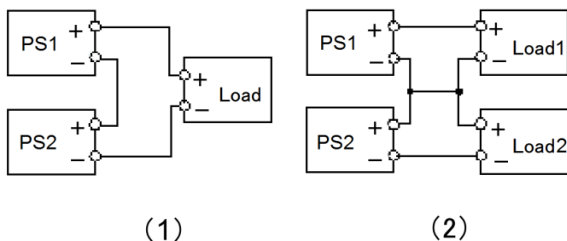

## 2-10 Parallel Operation

- This power supply can not be configured in parallel with another power supply.

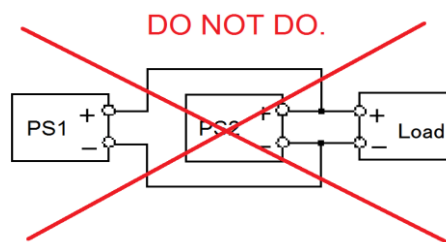

## 2-11 Ripple

- Maximum ripple voltage is measured using JEITA measurement method prescribed in RC-9131C.
- If ripple noise becomes excessive due to line length, connect an electrolytic capacitor (47μF) and film capacitor (0.1μF) at load side as shown.

The maximum ripple voltage in the standard specification is a value measured using the specified measuring circuit in the anechoic chamber under the JEITA measuring method (See the drawing). When the load line is long, the ripple on the load edge may become large unless a capacitor, such as an electrolytic capacitor or a film capacitor is connected. The output ripple cannot be measured accurately if the ground lead of the oscilloscope is too long.

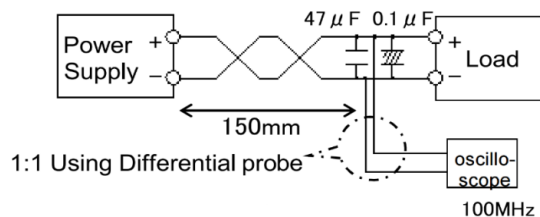

### Ripple measurement method

Ta=25°C Vin=100Vac, Typical value at the rated output

### 3. Mounting Method

#### 3-1 Mounting orientation

- Four possible mounting configurations:

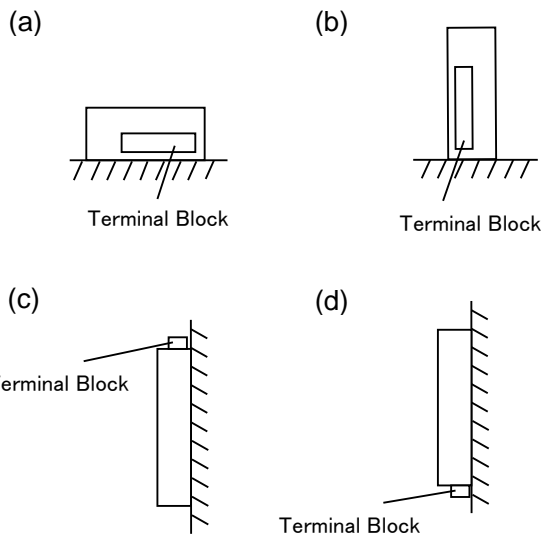

#### 3-2 Output derating

- For the four possible mounting configurations and varying temperatures of operation, please refer to below curve:
- Please see proper derating curve based on your application and model number under conditions of 2.0m/s airflow being applied as shown below:
- Mounting direction (a), (b), (c), (d)
- By derating the output power (loading rate), this product can be used in a wide temperature range.

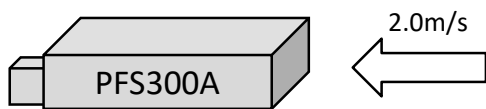

- To meet the requirement of 62368 or 60950  
PFS300A-12

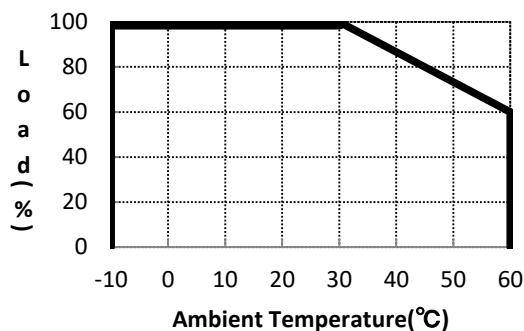

- PFS300A-15, 24, 30, 48

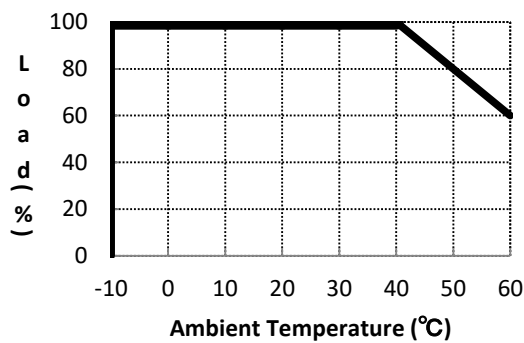

- For Medical 60601  
PFS300A-12

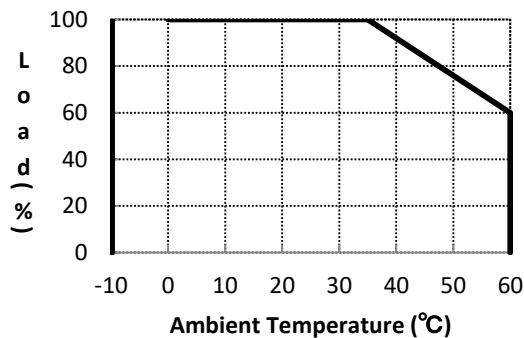

- PFS300A-15, 24, 30, 48

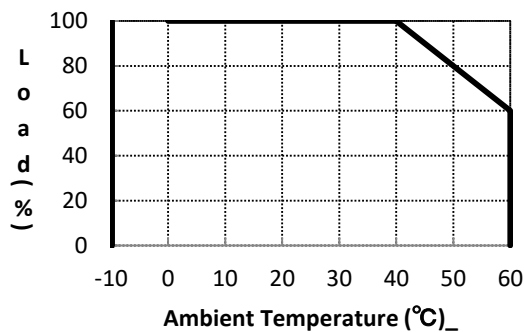

### 3-3 Temperature limitation of each components surface

If you need to calculate more in detail to choose suitable a far for your application, please refer to information below.

- Please address specific temperature range of each component.
- Please test under worst case conditions.
- The lower the input voltage is, the more heat tends to generate.
- Please ensure a Type K thermocouple is securely attached and anchored during temperature measurement.
- Please measure under no air flow conditions and at highest temperature spot throughout a range of temperatures to ensure stable operation.

Measured components

P/N	Component name	Max Temp (degree C)
C101	X Capacitor	100
L101	Common mode choke	110
D101	Bridge Diode	115
SCR101	Thyristor	105
TH101	Poly Switch	85
Q101	MOS-FET	115
D102	Diode	115
Q301	MOS-FET	105
TH301	Poly Switch	85
T301	Transformer (Primary side coil)	110
T301	Transformer (Secondary side coil)	110
PC501	Photo Coupler	100
D501	Secondary side Diode	115

\*Refer to the following drawing to specify each component location.

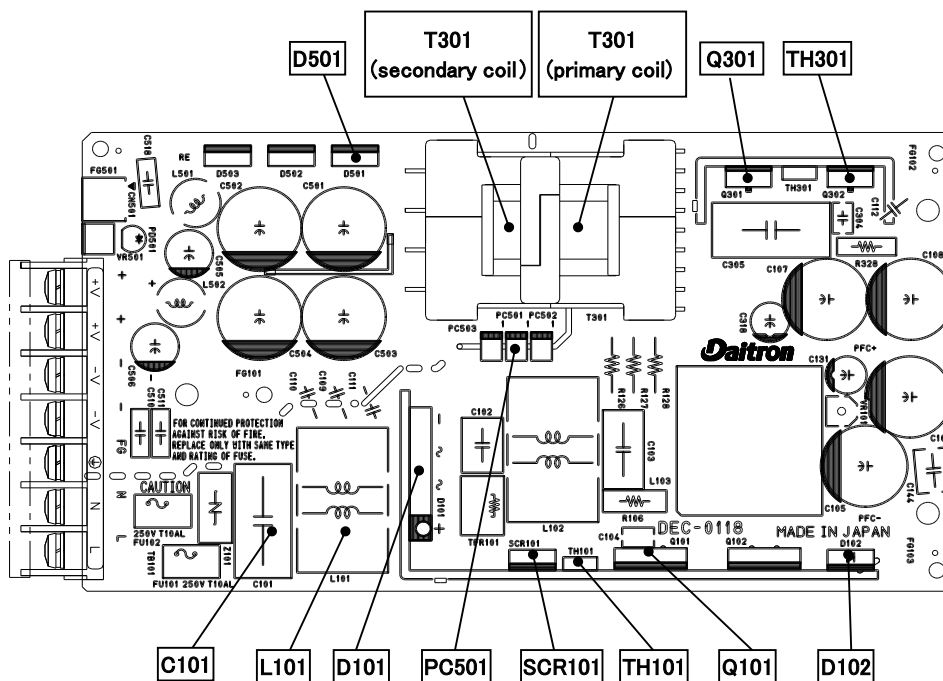

< Image from the top view >

### 3-4 Mounting method

- Forced air cooling method requires air flow from external fans.
- The insertion length of the power supply mounting screw should be 6mm or less.
- Recommended tightening torque for M4 power supply mounting screws: 1.4Nm

## 4. Connections

---

- Using twisted pairs for I/O and routing them separately from output load wire is ideal to minimize noise interference.
- For improved noise filtering, add lower value of electrolytic capacitor (Section 2-11, 47 $\mu$ F)
- Minimize length of output load wiring.
- Connect FG terminal with earth ground of system using power supply using minimal length possible.
- Recommended tightening torque for M4 terminal screws is 1.4Nm/1.03lbf
- To minimize noise interference, be sure to separate the output load line, remote control line, and remote sensing line from the input line. Noise immunity can be also improved by twisting each line.
- Attaching a small volume electrolytic capacitor to the load end is also effective to eliminate noise.
- For safety and noise prevention, ensure a secure grounding connection from ground terminal to equipment enclosure using appropriate wire size. Otherwise, it may cause electric shock.
- Recommended tightening torque for M4 I/O terminal screws: 1.4Nm
- Shut off the power, and carefully make connections for the remote sensing function. Incorrect wiring or poor connection could cause malfunction.
- Be sure to use each terminal (pole) of the terminal block at 20A or less.
- For the loading current of 20A or larger, use two terminal poles at the same time.

## 5. Troubleshooting

---

- Confirm input AC voltage to be within spec of 100-240VAC/50-60Hz.
- Confirm all input and output connections are in accordance with above.
- Check the output adjustment potentiometer. Sometimes output OVP function turns off the output power when the potentiometer is adjusted too high.
- Please note that an excessive capacitive load can create over current situation.
- Confirm remote on/off is getting the appropriate voltage for desired operation.
- Before suspecting a failure.
  - Check if the rated input voltage is connected.
  - Check if the input/output wiring is appropriate.
  - Check if the wire material is not too thin.
  - Check if a large-capacity capacitor is not connected to the load side.
  - Check if the remote control is not active.
  - Check if the accessory connector for CN501 is connected.  
The accessory connector is required if the remote sensing function is not used.
  - Check if forced air cooling by external fans is properly functioning.

## 6. Warranty

---

The warranty is valid one year from the date of the delivery, except for the following cases.

- 1) Repair is provided at a cost for the following cases even during the valid warranty period.
  - Failures or damage caused by misuse or unauthorized repair of the product
  - Failures or damage caused by transport after delivery.
  - Failures or damage caused by a fire, earthquake, wind and water, and other natural disasters, or abnormal voltage.
  - Failures caused by other devices connected.
- 2) For the use in special environments, such as salty, acid, alkaline, dusty, or corrosive environment, please contact us in advance.